

# W60 MOTOR

Compact in size,  
giant in performance

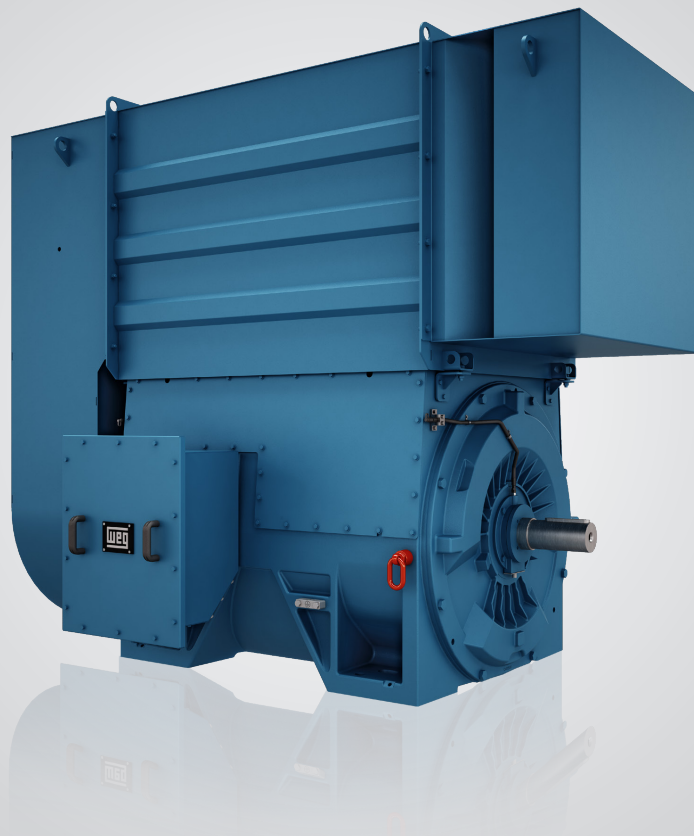

Motors | Automation | Energy | Transmission & Distribution | Coatings

## W60 - Three-Phase Induction Motor

WEG W60 motor line is designed for industrial applications such as compressors, pumps, fans and others, ensuring high performance and reliability even under the most severe operating conditions.

### Flexibility is the Key

W60 motors are available on three different configurations allowing it to be designed as an open, self-ventilated (IC01, WP-II) motor, or an enclosed, air-air cooled (IC611, TEAAC) or air-water cooled (IC81W, TEWAC) motor.

### Compact Design

With its compact design, lightweight components, reduced dimensions and footprint that saves valuable space on the skid or base where the motor is installed, the W60 is the most compact modular motor in the market.

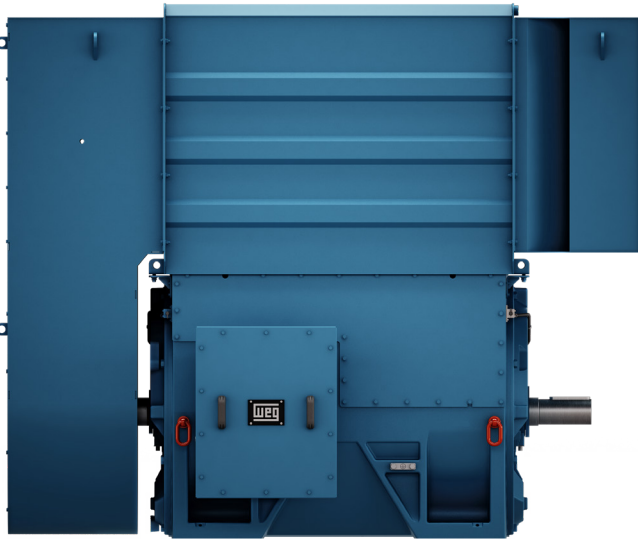

### Severe Duty is Standard for W60

A rugged motor made with high quality cast iron frame and end shields fitted with antifriction bearings up to 560 IEC frame guarantees the lowest vibration and noise levels.

On larger frames, the same results is achieved by means of a dedicated steel fabricated frame, associated with carefully selected sleeve bearings.

### Outstanding in the Market

WEG engineers have developed a unique product that combines the latest technology of high quality rotor and stator lamination, low losses fans and optimized heat exchanger, increasing considerably the power density rate (output per weight). This combination makes the W60 your best choice for an energy efficient motor.

### Reliability Where you Need It

Designed to operate continuously without interruption, the W60 was conceived with unique characteristics: easy to build, easy to assemble, easy to install.

### VFD Friendly

The W60 adapts easily to any medium voltage VFD in the market. Suitable to operate with no speed limitation up to rated speed by standard design. An optimized insulation is available when combined with WEG medium voltage variable frequency drive.



## Product Scope

- Rated output: 185 up to 16,000 kW
- Number of poles: 2 up to 12
- Frame sizes: IEC 315 up to 1000
- Voltage: 400 up to 13,800 V
- Frequency: 50 or 60 Hz
- Mounting: Horizontal
- Cooling method: IC01, IC611, IC81W
- Degree of protection: IP24W up to IP55
- Starting: DOL or VFD

## Standard Features

- RTD Pt-100, two per phase
- RTD Pt-100, one per bearing
- Space heater
- Copper bars rotor
- Global VPI Insulation System



## Optional Features

- Certifications for use in non-hazardous areas: CE, UL, CSA, EAC, GOST-R
- Certifications for use in hazardous areas:
  - Ex ec IIB or IIC T3 or T4 Gc (increased safety, level of protection "ec")
  - Ex eb IIB or IIC T3 or T4 Gb (increased safety, level of protection "eb")
  - Ex tc IIIB or IIIC T125 °C or T160 °C Dc (dust ignition protection by enclosure "t")
  - Ex tb IIIC T125 °C or T160 °C Db (dust ignition protection by enclosure "t")
  - Ex pzc IIB or IIC T3 or T4 Gc (pressurized enclosure)
  - Ex pxb IIB or IIC T3 or T4 Gb (pressurized enclosure)
  - Class I, Division 2, Groups A, B, C and D, Temp. Cod. T3B or T3C or T3 (non-incendive)
  - Class II, Division 2, Groups F and G, Temp. Cod. T3B or T3C (dust ignition proof)
- Cooling method: IC06, IC86W, IC616 and IC666
- Degree of protection: IP56 and IP65
- Air filters
- Differential pressure switch (air cooled)
- Water leakage detector (water cooled)
- Thermometers
- Encoder (VFD operation)
- Surge protection (lightning arrestors and capacitors)
- Vibration sensors (acceleration, velocity and displacement)
- Several others available upon request

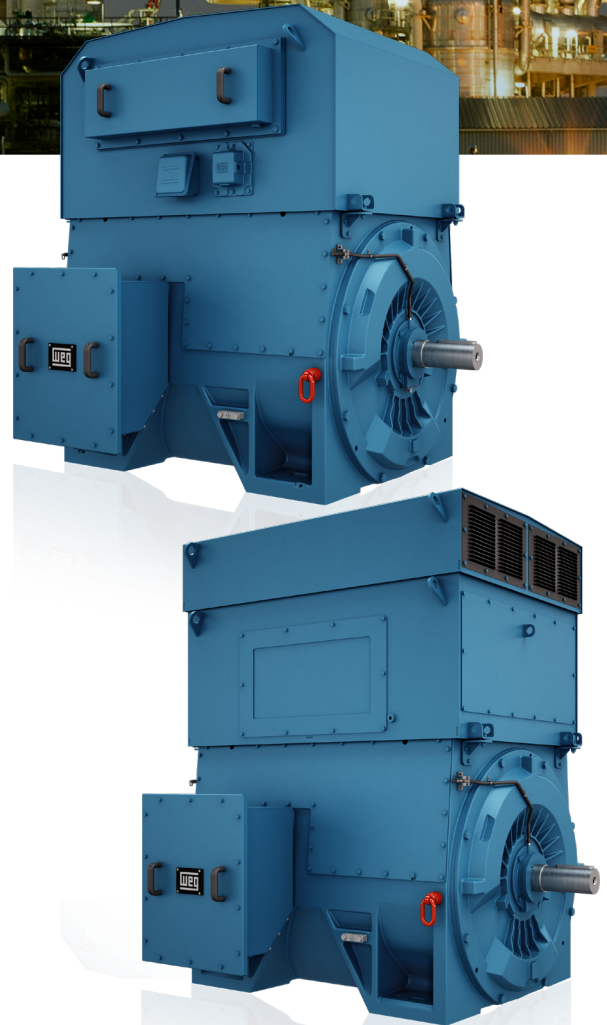

### Certifications



## Design Details

### Electrical Performance

With an optimized concept for heat exchanging and magnetic flow, the W60 allows several different configurations that suits all sort of applications, from self-cooled to forced ventilation.

#### Cooling System

- Increased air flow
- Low losses fans
- Easy assembly
- Mechanically strong

#### Electrical Core

- High quality lamination
- Energy efficient
- Increased power density ratio

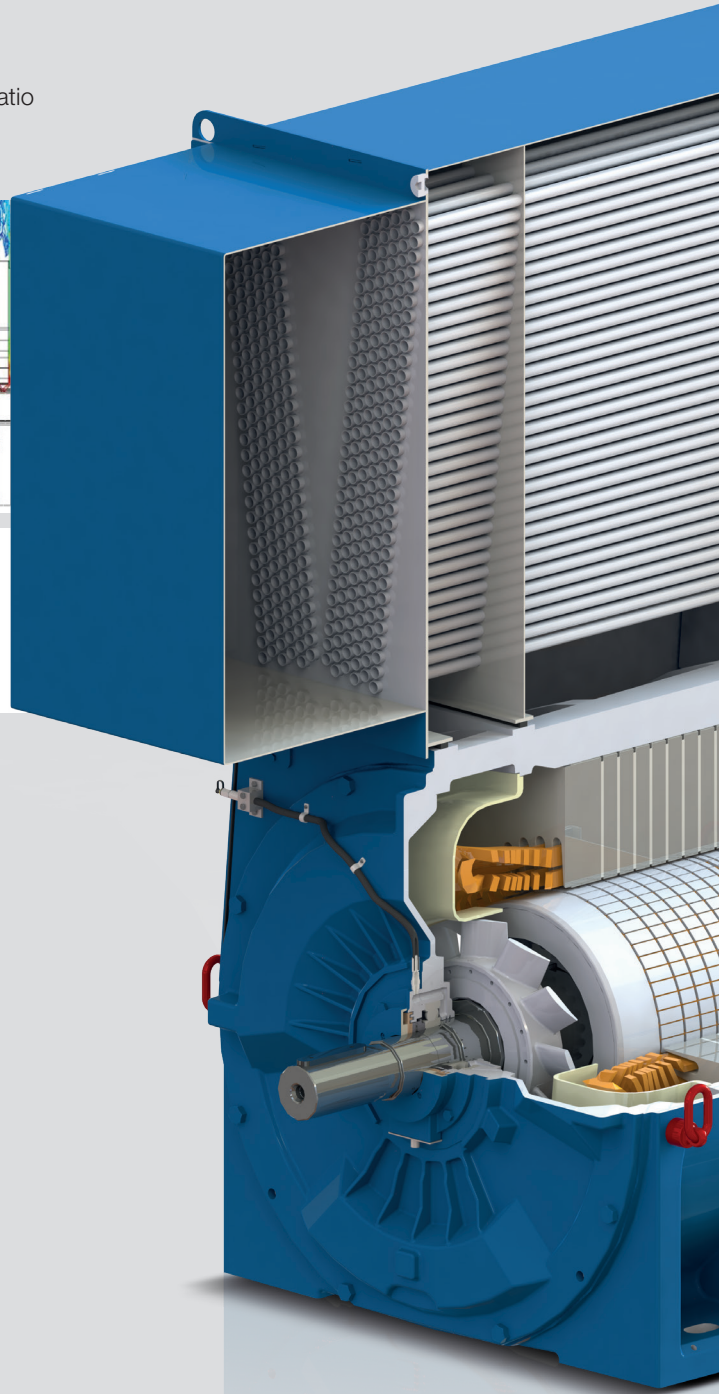
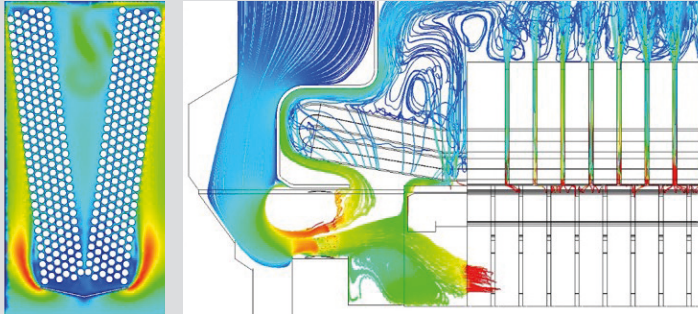

### Bearings

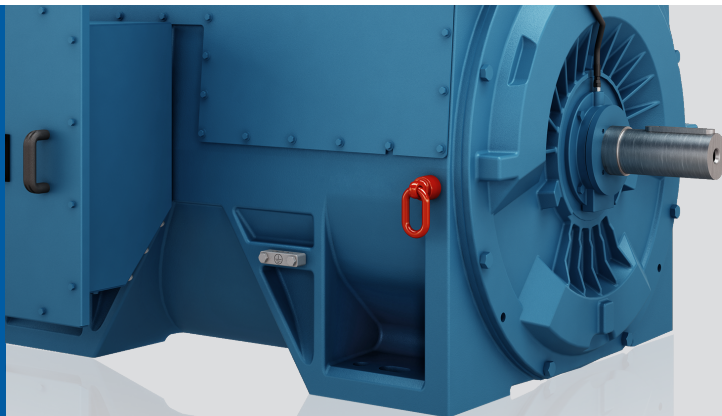

Ball bearings are standard up to 560 frame even on 2 pole motors. Its compact design allows utilization of antifriction ball bearings, grease lubricated, where other motors cannot.

Sleeve bearings are standard for larger 2 and 4 poles motors and are available when required for the entire range.

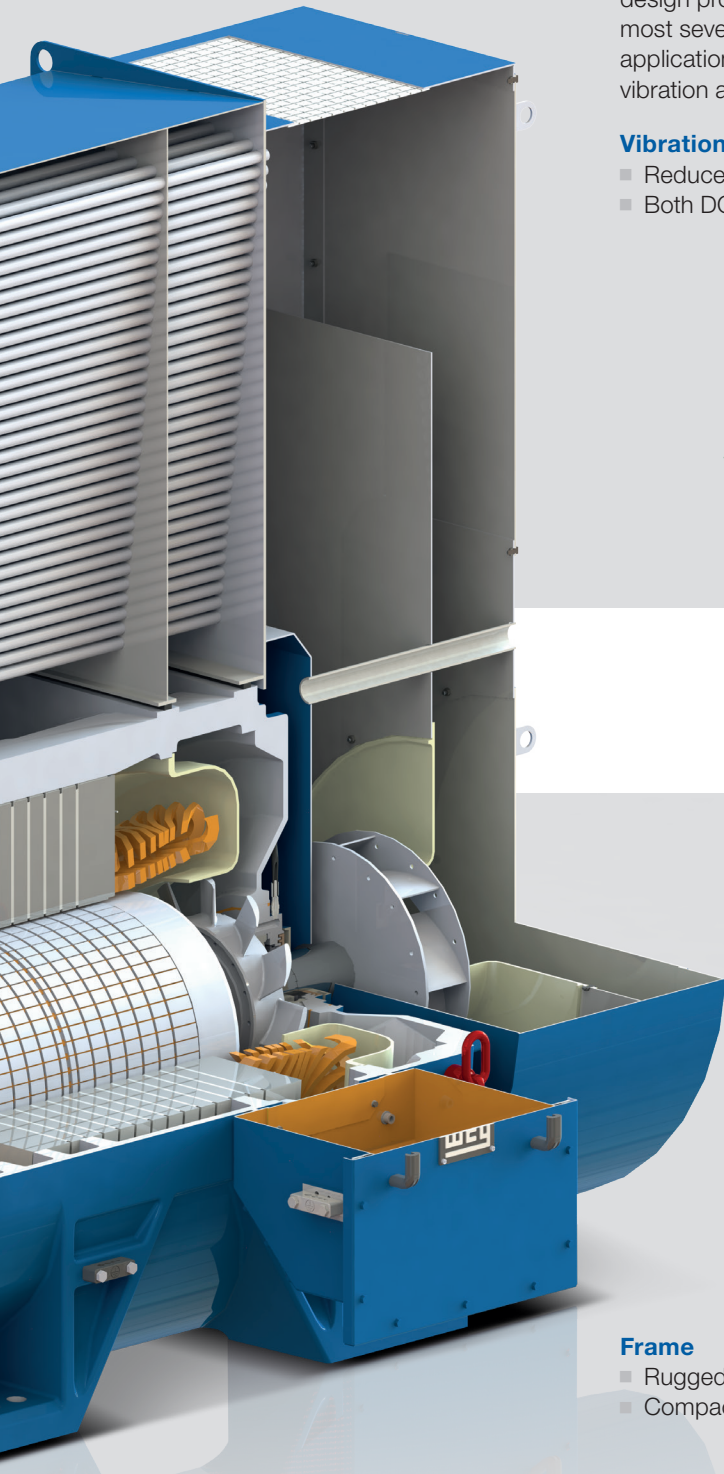

Designed using the most advanced software the W60 frame design provides a solid structure that allows operation in the most severe environments, suitable for high impact and speed applications, while providing a smooth operation, with low vibration and noise levels.

**Vibration Level**

- Reduced vibration levels
- Both DOL and VFD operation

**Noise Suppressors**

- Carefully designed system
- Superior noise cancelling
- Simplified assembly
- Easy maintenance

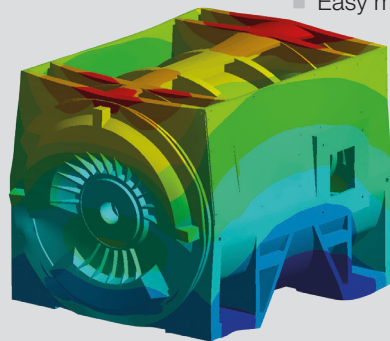

Mechanical Features

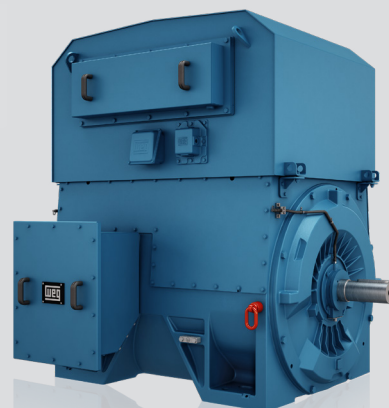

**Frame**

- Rugged design
- Compact and lighter

**End Shields**

- Reinforced structure
- High quality cast iron

Compact and Robust

## Test Laboratory

WEG motors are tested according to NBR 5383, IEC 60034, NEMA MG 1 and API in modern laboratories. Capable of testing low and high voltage motors with power up to 20,000 kVA and voltages up to 15,000 V, WEG laboratories feature highly accurate controls and fully computerized test monitoring systems.

The tests are divided into three categories: routine, type and special tests. Routine tests are performed in all motors. In addition to routine tests, type and special tests are usually performed in one of a series of the same motors or under the customer's request.



Surge test



Control room



Test laboratory

## Technical Assistance

WEG technical team provides the customers with full after sale support. The services include consulting in general and services in the field, such as diagnosis, commissioning of machines and 24x7 support. The technical assistance team is highly qualified and experienced, able to handle many different situations in the field and to give remote support, using state-of-the-art equipment, which ensures reliable results. WEG also provides its network of authorized repair shops, present in Brazil and worldwide.



## Services

In order to restore medium and large electrical machines, count on WEG service team. The same technology used to manufacture motors and generators is used for inspection and restoration. The services are executed in the field (at the customer's premises) or at the factories in Jaraguá do Sul/SC, Sertãozinho/SP and São Bernardo do Campo/SP, which are also homologated to execute services on equipment for use in explosive atmospheres. These plants count on the full structure and support of the engineering, industrial process and quality control departments, enabling fast, reliable and quality service.

Service of **WEG products** and other brands:

- DC generators and motors
- Three-phase induction motors (squirrel cage or slip ring; medium and high voltage)
- Synchronous motors (with or without brushes; medium and high voltage)
- Synchronous condensers
- Turbogenerators
- Hydrogenerators
- Wind turbines
- Steam turbines
- Hydraulic turbines

**WEG Services:** Flexibility, agility and experience to optimize your time and productivity.

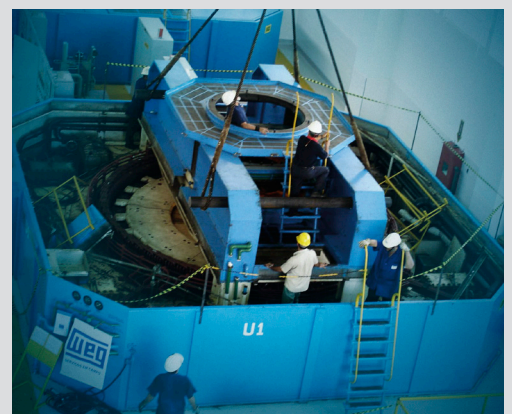

For WEG's worldwide  
operations visit our website



[www.weg.net](http://www.weg.net)



 +55 47 3276.4000

 [energia@weg.net](mailto:energia@weg.net)

 Jaraguá do Sul - SC - Brazil

Cod: 50043982 | Rev: 05 | Date (m/a): 06/2021.

The values shown are subject to change without prior notice.  
The information contained is reference values.